

**MODELLO
CINQUE**
Ref. U5S-MoMA-B

*Limited edition of 75 pieces
Made in Italy
2 years warranty*

UNIMATIC®

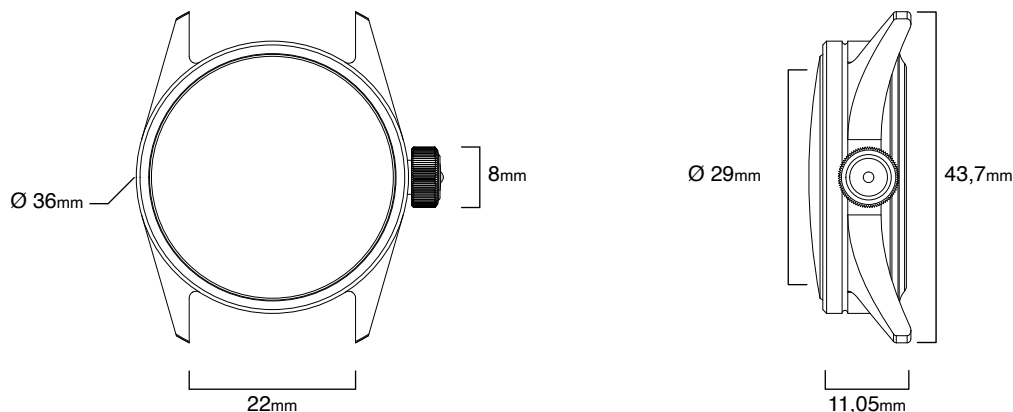

PRODUCT NAME	Modello Cinque U5S-MoMA-B
TYPE	UNIMATIC x MoMA
WATER RESISTANCE	300m = 1000ft = 30atm WR
ORIGIN	Made in Italy
TESTING	Singularly tested for accuracy and water resistance
EDITION	Individually numbered, edition of 75
CASE SIZE	Diameter 36mm
LUGS / STRAP SIZE	22mm
CASE MATERIAL	316 stainless steel
CASE FINISHING	Brushed finish
CASEBACK	UNIMATIC x MoMA screw-down caseback
CROWN	Alchemical Sun ☉ 8mm screw-down
LENS DESCRIPTION	2.2mm thick double domed sapphire
LENS TREATMENT	Inner side anti-reflective coating
DIAL	Matte white dial with matte black MoMA logo
LUMINOUS	Super-LumiNova® C1
DIAL FEATURES	Matte black markers, open second rail and dial trims
HANDS	Primary yellow ladder H, primary blue M, primary red reverse lollipop S, Super-LumiNova C1 tip
CALIBER TYPE	Automatic calibre Sellita SW200-1 b
CALIBER FREQUENCY	28800bph
CALIBER FEATURE	Hacking seconds hand
CALIBER WINDING	Self-winding/ manual winding
CALIBER JEWELS	26
MIDDLE RATE ACCURACY	-20 ~ +30s/day
POWER RESERVE	Min 38h, typical 41h
ANTIMAGNETISM	Antimagnetic ≥ 4800 A/m
STRAP	Primary blue leather quick-release two-piece strap
EXTRA STRAP	Black tapered quick-release two-piece TPU strap
HARDWARE	Stainless steel brushed hardware signed UNIMATIC
PRODUCT KIT	UNIMATIC tough case, warranty card with unique ID seal